

Description	Diaphragm-operated pressure regulator completely made of stainless steel for very low outlet pressure, independent of inlet pressure.		
Note	It is recommended to select an outlet diameter at least one time larger than the main valve's diameter. Mounting position with spring cage downward at pressure range < 100 mbar.		
Media	compressed air or gases		
Supply pressure	max. 25 bar at R74-02 to -A8,	max. 16 bar at R74-08/16	
Adjustment	by T-handle with locknut		
Relieving function	non-relieving		
Gauge port	G $\frac{1}{4}$ on both sides of the body	Mounting position	spring cage downward
Temperature range	0 °C to 140 °C / 32 °F to 284 °F for EPDM, steamable		
Material	Body: stainless steel 1.4301, optionally 1.4435	Spring cage:	stainless steel 1.4301
	Diaphragm: EPDM	Seals: EPDM	O-rings: EPDM

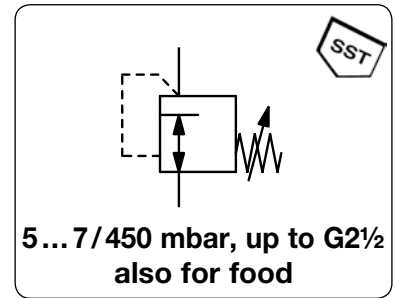

Dimensions			Nominal K _v -size	Flow rate		Connection thread	Diaphr. Ø	P ₁ recommended	Pressure range	Order number
A	B	C	DN	(m ³ /h)	air l/min*1	water l/min*2	G	Ø mm	< bar	mbar

Low pressure regulator											supply pressure max. 16 / 25 bar, non-relieving, without constant bleed	R74
70	368	48	8	1.2	30	1.8	G $\frac{1}{4}$	405	0.5	5 ... 9	R74-02A	
									0.5	8 ... 15	R74-02B	
									0.5	14 ... 28	R74-02C	
							R74-03 for G $\frac{3}{8}$	310	0.8	25 ... 33	R74-02D	
							R74-A4 for G $\frac{1}{2}$	235	1.2	28 ... 56	R74-02E	
								190	1.5	50 ... 74	R74-02F	
									2.0	60 ... 120	R74-02G	
									4.0	100 ... 150	R74-02H	
									25	130 ... 266	R74-02I	
									25	230 ... 450	R74-02K	
70	368	48	10	2.0	30	1.8	G $\frac{3}{8}$	R74-03.	
70	368	48	15	2.2	30	1.8	G $\frac{1}{2}$	R74-A4.	
90	368	58	15	3.0	120	7.2	G $\frac{1}{2}$	405	0.5	5 ... 8	R74-04A	
									0.5	8 ... 15	R74-04B	
									0.5	13 ... 27	R74-04C	
							R74-06 for G $\frac{3}{4}$	310	0.8	25 ... 32	R74-04D	
							R74-A8 for G1	235	1.2	27 ... 54	R74-04E	
								190	1.5	50 ... 70	R74-04F	
									2.0	60 ... 100	R74-04G	
									4.0	100 ... 140	R74-04H	
									25	130 ... 250	R74-04I	
									25	220 ... 400	R74-04K	
90	368	58	20	3.2	120	7.2	G $\frac{3}{4}$	R74-06.	
90	368	58	25	3.5	120	7.2	G1	R74-A8.	
105	388	68	25	6.3	370	22	G1	405	0.5	5 ... 8	R74-08A	
									0.5	7 ... 14	R74-08B	
									0.5	13 ... 25	R74-08C	
							R74-12 for G1 $\frac{1}{2}$	310	0.8	25 ... 30	R74-08D	
								235	1.2	28 ... 50	R74-08E	
									1.4	50 ... 65	R74-08F	
									2.0	60 ... 110	R74-08G	
								190	5.0	100 ... 140	R74-08H	
									16	120 ... 230	R74-08I	
									16	210 ... 400	R74-08K	
105	388	68	32	6.5	370	22	G1 $\frac{1}{4}$	R74-10.	
105	388	68	40	6.7	370	22	G1 $\frac{1}{2}$	R74-12.	

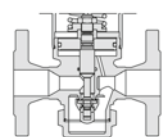
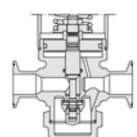
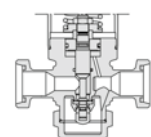
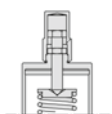

*1 at 10 m/s flow velocity
*2 at 1.5 m/s flow velocity

Pharmacy and food-safe version

Description	The pharmacy version (option P) standard design is completely made of stainless steel, independent of inlet pressure, sealed at zero consumption, with EPDM and steamable up to 140 °C / 284 °F. Media contact parts have roughness of $R_a < 2.6 \mu\text{m}$.					
Special options	Add the appropriate letter to the order number:					
Outer surface	Valve body: electropolished	FA	glass bead shot-peened	FC		
	Complete valve: electropolished	FB	glass bead shot-peened	FD	ground/polished $R_a 1.2 \mu\text{m}$	FE
Inner surface	Valve body: $R_a < 2.0 \mu\text{m}$		glass bead shot-peened	GA		
	Media contact parts: $R_a < 1.6 \mu\text{m}$	GB	$R_a < 0.8 \mu\text{m}$	GC	$R_a < 0.5 \mu\text{m}$	GD
Connection	Aseptic flange as per DIN 11864-2	F(AS)	as per APV	F(APV)		
	Flange as per DIN 2633 (PN16)	F	as per ANSI B16.5 150 lbs	F150lbs		
	Threaded connection as per DIN 11851	GA				
	Clamp fittings as per DIN 32676	CL				

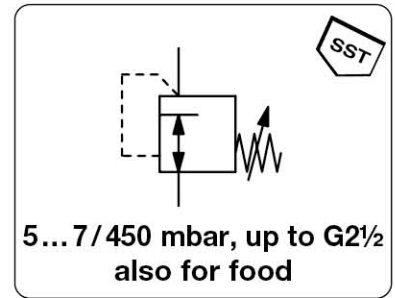

Dimensions			Nominal K_v -	Flow rate	Connection	Diaphr.	P_1	Pressure	Order	
A	B	C	size	value	air	water	thread	recommended	range	number
mm	mm	mm	DN	(m³/h)	l/min*1	l/min*2	G	Ø mm	< bar	mbar

Low pressure regulator

supply pressure max. 16 / 25 bar, non-relieving, without constant bleed

R74

145	435	85	50	13.0	1350	81	G2*	405	0.5	5... 7	R74-16A
									0.5	7... 14	R74-16B
									0.5	12... 24	R74-16C
									0.8	21... 26	R74-16D
								310	1.2	25... 28	R74-16E
									2.0	27... 45	R74-16F
									3.0	42... 50	R74-16G
								235	4.0	50... 63	R74-16H
									16	60... 110	R74-16I
									16	100... 180	R74-16K
									16	160... 300	R74-16L
145	435	85	40	12.5	1350	81	G1½	R74-B2.
145	435	85	65	13.5	1350	81	G2½	R74-20.



R74-08IF



R74-16A

Special options, add the appropriate letter

NPT	connection thread	R74-...N
stainless steel 1.4435	housing 1.4435, spring cage 1.4301 for G¾ up to G1	R74-...S
tamper-proof cap	adjustment by spanner, height 40 mm lower	R74-...T
drainage	through bottom screw	R74-...U
volume booster	pneumatic pressure setting	R74-...J
other connections	DIN or ANSI flange, threaded connection or clamp fittings	R74-...F.
for pharmacy	forged stainless steel, $R_a < 2.6 \mu\text{m}$, steamable, EPDM	R74-...P
for food industry	EPDM elastomer with FDA approval	R74-...

Accessories, enclosed

pressure gauge Ø 63 mm, 0...*3 mbar, G¼, capsule type, 0...100 °C/32...212 °F **MS6302-..*3**
for other requirements on request

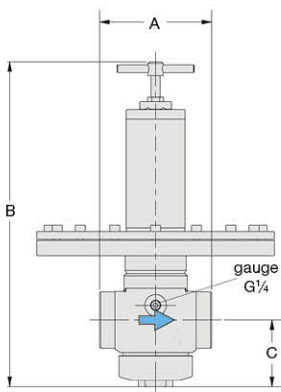

R74

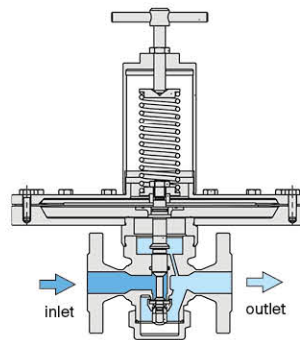

cross-section

*1 at 10 m/s flow velocity

*2 at 1.5 m/s flow velocity

*3 B2 = 0...25 mbar, B6 = 0...60 mbar, C1 = 0...100 mbar, C3 = 0...250 mbar, C4 = 0...400 mbar, C6 = 0...600 mbar

Gauges: see chapter for measuring devices

PDF CAD
www.aircom.net



Order example:
R74-16A